

EQ1 Motor Drive

INSTALLATION

- 1) Rotate fine-adjust cable until the setscrew faces upward as seen in the diagram.
- 2) Remove R.A. fine-adjust cable from equatorial mount.
- 3) Loosen set screw on end of the flexible motor coupler using the 2mm hex key provided.
- 4) Slide the open end of the flexible motor coupler over the R.A. axis worm gear. Ensure set screw seats against flat surface on R.A. worm gear. Fasten set screw to secure motor coupler.
- 5) Use the 4mm hex key to remove hex screw from altitude axis.
- 6) Fasten motor drive mounting bracket to altitude axis using 4mm hex screw.
- 7) Plug 5-pin DIN cable from hand control box into motor.
- 8) Plug DC power cord from battery case into power outlet on control box.

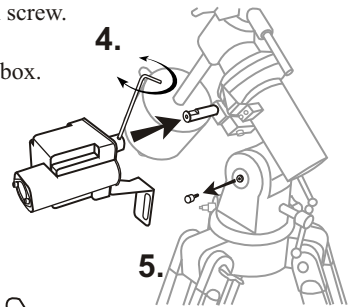
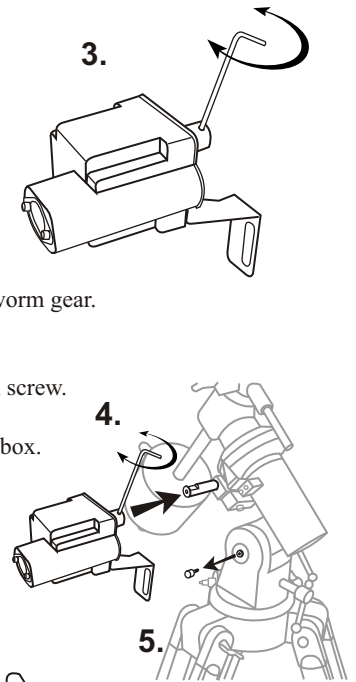
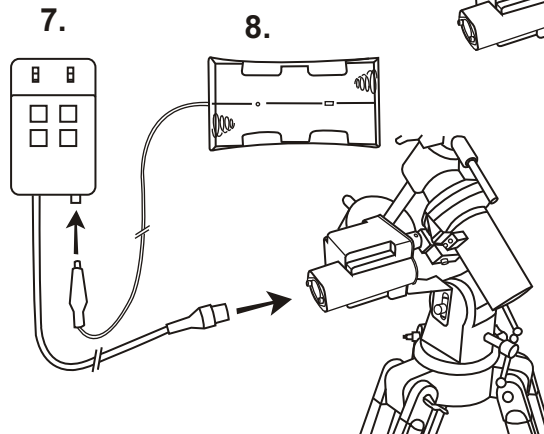
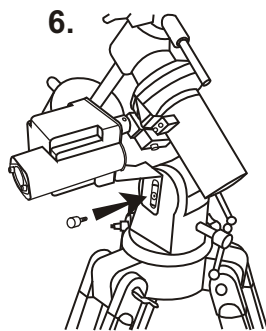
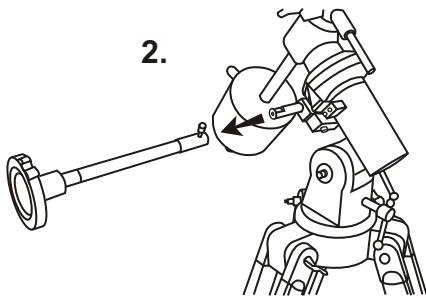
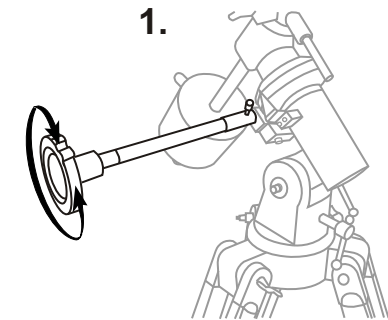

OPERATION

A motor drive allows tracking of celestial objects. Tracking corrects for rotation of the earth by rotating the telescope at about the speed of an hour hand on a clock. The single axis drive unit is known as a clock drive. For polar-aligned equatorial mounts, the motor drive will correct for earth's rotation. The hand controller can be used as a correction for long exposure photographs. For the motor drive to properly compensate for the earth's rotation, your telescope mount must be polar-aligned and the altitude axis set to your local latitude. Under these conditions, no adjustment of the declination axis should be necessary for astrophotography. You will only need the R.A. motor drive.

When the power is on and all buttons on the control box are depressed, the motor drive will automatically rotate at the correct speed to compensate for the rotation of the earth. Its rotation speed matches the earth's rotation rate for stars to appear stationary in telescope eyepiece.

The on/off switch controls power for the motor drive. The N/S switch changes direction of motor tracking. The "S" setting should be used for observing in the Southern Hemisphere.

The motor drive requires 4 'D' cell batteries (not included) to operate. A set of batteries will allow several nights of observing. The LED light is green under normal operation. The LED begins to flash in the case of imminent battery failure.

The right "2X" button will rotate the telescope forward at twice the tracking speed or approximately $\frac{1}{2}^\circ$ per minute. The left "2X" button stops all motion and allows stars to drift by at their normal rotation rate of approx. $\frac{1}{4}^\circ$ per minute. The "8X" buttons allows forward at eight times the tracking rate (approx. 2° per minute) and the reverse button move the telescope backwards at seven times the tracking rate (approx. $1 \frac{3}{4}^\circ$ per minute).

The tracking speed of the R.A. motor is factory set and should not need adjustment. Adjustment of the variable resistor inside the control box should be performed by an experienced technician.